



BERTIE MODULAR LOUNGE

BERTIE MODULAR LOUNGE



Yes, the Bertie is big and bold. However, with elegant lines and constrained cushioning providing an understated and considered aesthetic, so too is it surprisingly compact when viewed in person.

At home amongst the modernist architectural movement, the Bertie fits beautifully among a palette of timber, concrete and metal tones. This modular lounge is not dramatic or ostentatious. Rather it is composed and clean-cut, with a comforting angular quality balanced by small details such as the inward curve of the backrest. In this way it can step beyond the realm of stark minimalism and into a world of depth and functional style.

Fine metal legs are balanced against the sumptuous upholstery, which is backed by a built to last framing structure and commercial quality foam. Available in a range of configurations to fit multiple spatial plans, and with an optional wool wrap between the foam and outer cover, the Bertie a no-fluff, all-style piece that is simple, straightforward, and happy to complement more ostentatious pieces with measured ease.

DIMENSIONS (CM)	WIDTH	DEPTH	HEIGHT
2.5 Seater Settee	231	91	71
3 Seater Settee	257	91	71
3.5 Seater Settee	280	91	71
End Unit Triple (LH/RH arm)	227	91	71
End Unit Twin (LH/RH arm)	163	91	71
Triple Chaise (LH/RH chaise)	292	91	71
Twin Chaise (LH/RH chaise)	228	91	71
Seat height			44
Seat depth (without lumbar cushion)		59	
Lumbar Cushion (optional)	66	30	75
Side Arm Cushion (optional)	55	30	75

BERTIE MODULAR LOUNGE SETTEES

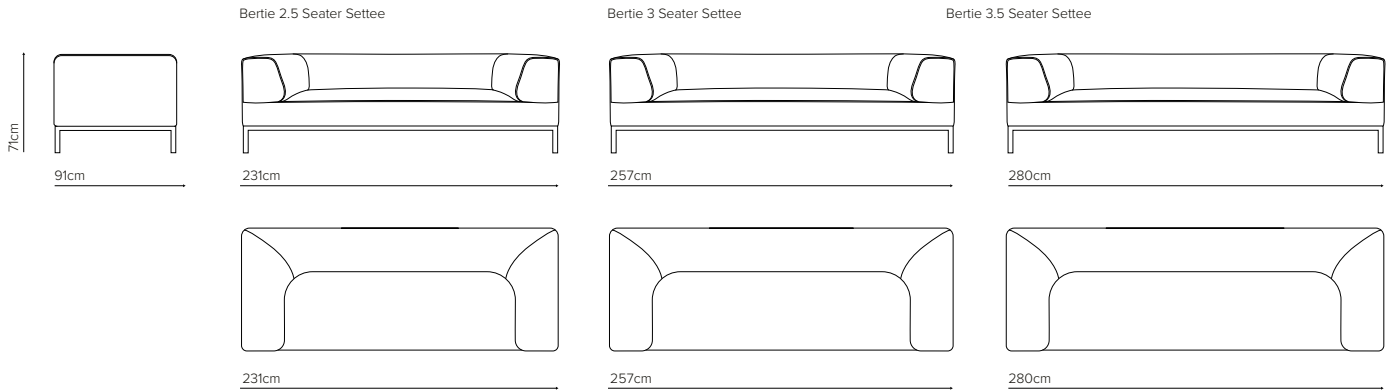

BERTIE MODULAR LOUNGE MODULAR

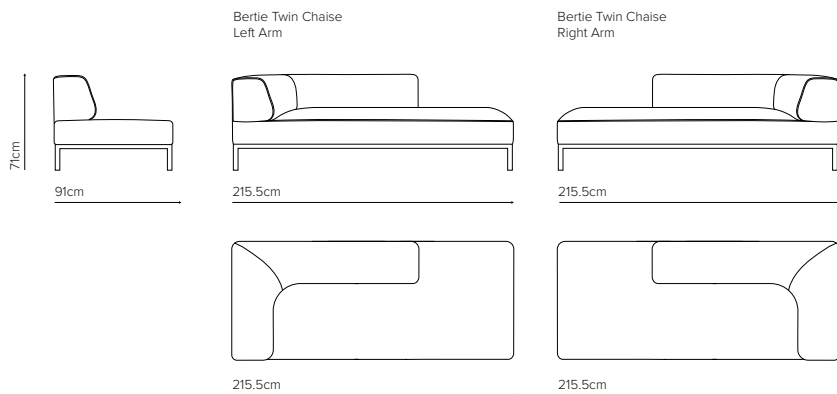
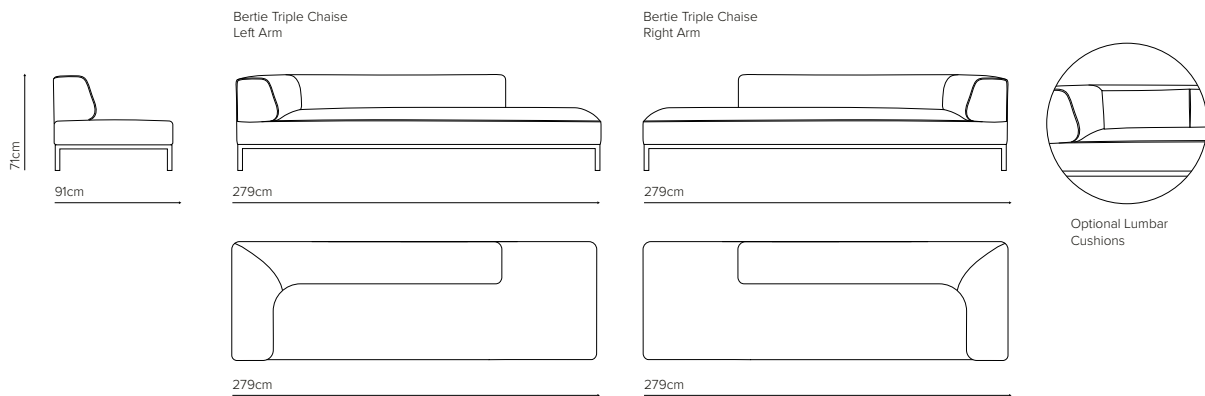
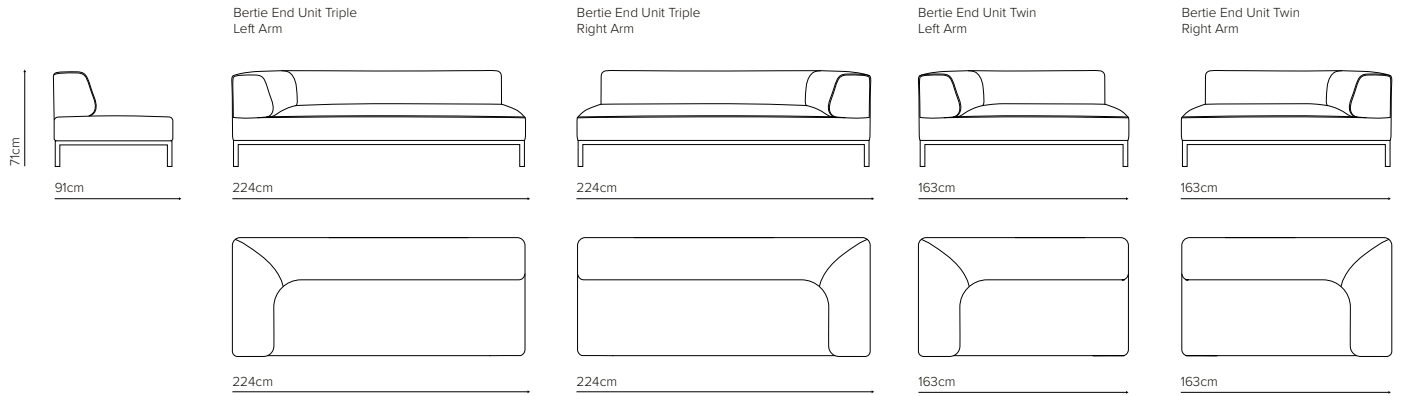

BERTIE MODULAR LOUNGE COMPOSITION EXAMPLES

